



SINGLE USE MIXING SYSTEM



» EFFICIENCY REDEFINED –

Configurable and scalable to suit a wide range of applications and end user needs. **OneSUM** is powered by **OnePump VersaFlow technology**, allowing users to simultaneously fill, mix, and monitor products using one control unit.

Single Use Mixing System



VIEW ONESUM
ON WEBSITE

Introduction

OneSUM Single-use mixer employs a magnetically driven levitating impeller to enable robust blending, contact-free mixing of liquids, powders, and other materials critical for biopharmaceutical formulations. The bottom mount design allows for ultra low level mixing particularly during pump out/draw down. Efficient mixing is precisely monitored and controlled through optional instrumentation including pH, conductivity, temperature, and weight. OneSUM single-use bags are configurable to suit each users unique needs and come pre-sterilized, reducing contamination risks and ensuring process reliability.

Versatile Mixing Solutions

- Buffer Preparation – Mixing buffers for chromatography, filtration, or other downstream processes
- Media Preparation - Mixing powdered or liquid media to create culture media for cell growth and upstream processing
- Product Formulation – Blending drug substances with excipients for final formulation
- Hydration – Dissolving powders, such as salts, sugars, or other ingredients into liquids for bioprocessing
- Viral Inactivation – Controlled mixing for viral inactivation during downstream processing
- Vaccine Manufacturing – Preparing and blending adjuvants, antigens, or stabilizers for vaccine production



Advantages of OneSUM Mixer

- Elimination of Cleaning Requirements – Pre-sterilized disposable systems reduce the need for cleaning and validation, saving time and cost
- Minimized Cross-Contamination Risk – Single-use components ensure product integrity, especially in multi-product facilities
- Sustainability – Reduce water and energy consumption
- High Mixing Efficiency – Advanced technologies ensure homogeneity, even for challenging materials like powders or viscous solutions
- Scalability – Available in a wide range of volumes, enabling seamless scale-up from R&D to commercial production
- Process Flexibility – Easy to integrate into various biopharmaceutical processes
- Rapid Deployment – Reduced setup time compared to traditional stainless-steel mixers
- Cost Efficiency – Lower capital investment and operations costs compared to reusable systems



Modular Pump Heads

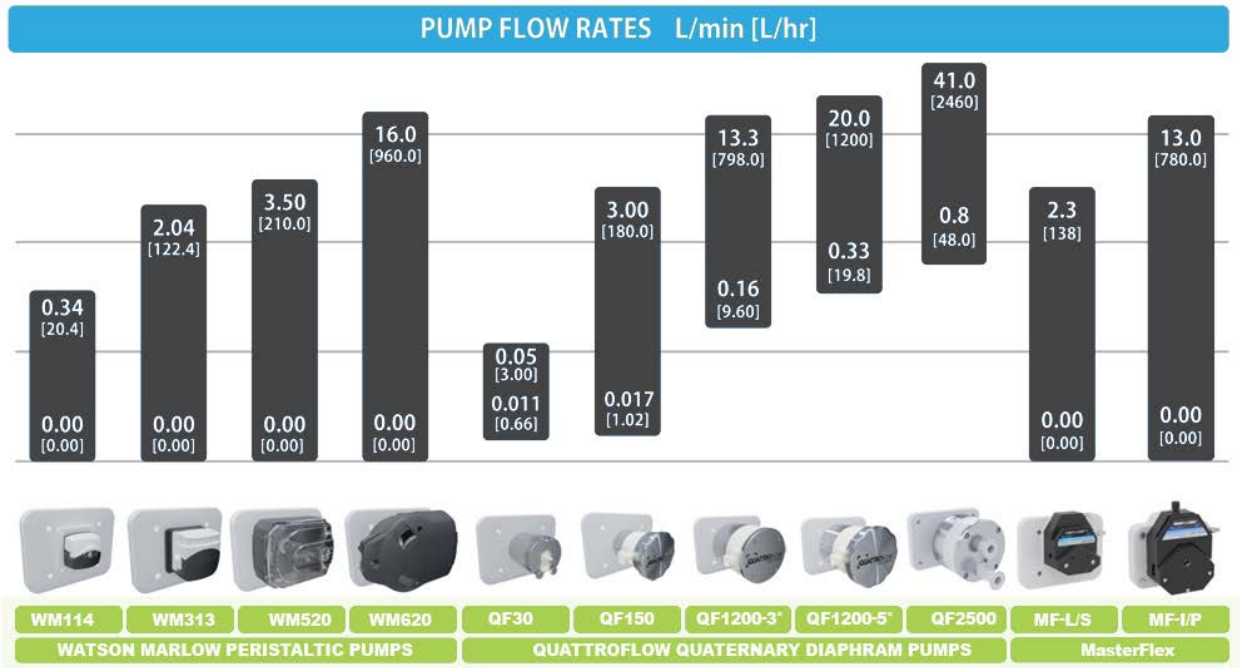

VersaFlow Mixer Cart

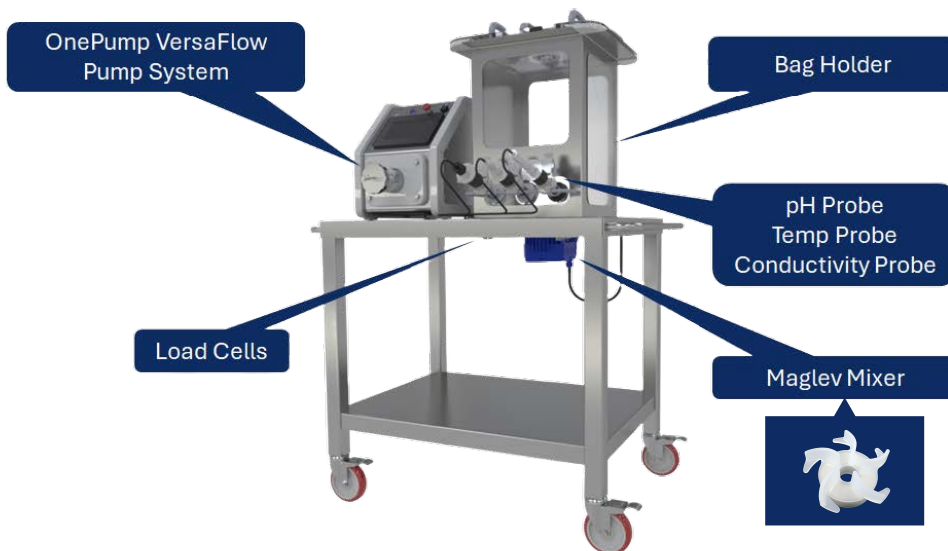

- OnePump Versatility – Control multiple pump technologies with a single control system
- Magnetic Levitating Mixer – Magnetically driven impeller for gentle, efficient mixing with minimal shear stress
- Brand Agnostic Sensor Integration – Compatible with a wide range of sensors for real-time process monitoring
- Load Cells – Real-Time measurement and monitoring (volume/weight)
- Temperature Control – Optional jacketed tank with heating and cooling

OneSUM Sensor, Meter, and Probe Configuration Options

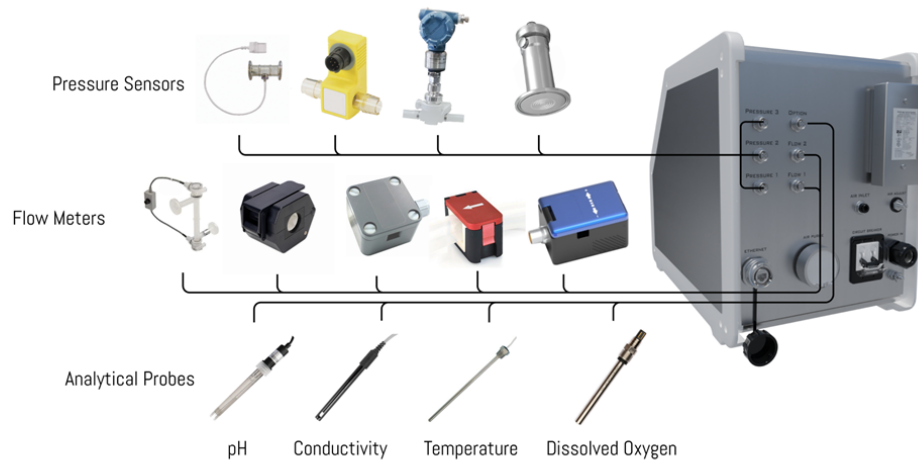

Standard Bag Configuration

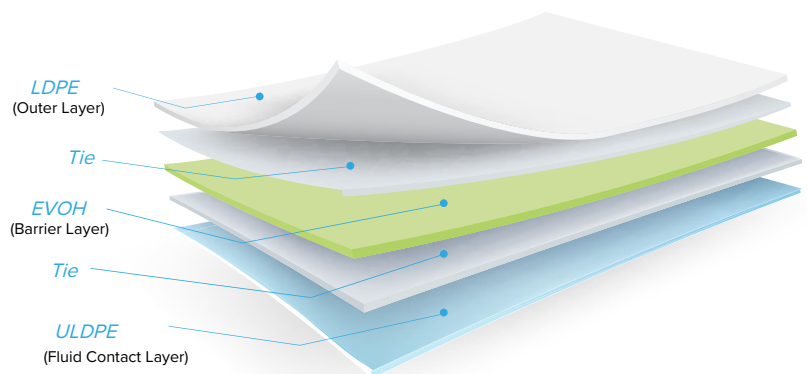
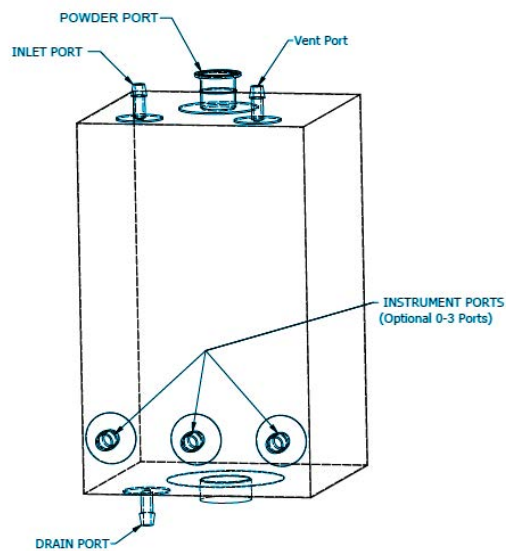

- **Customization** – Bags assembly designs are tailored to meet individual customer and process requirements
- **Single-Use Ecosystem** – OneSUM integrates seamlessly with other single-use technologies, such as OneSil and OneFlex tubing, filters, and bags, facilitating end-to-end single-use workflows

Multilayer Film Structure:

Purity One single-use bags are constructed of a 12.8 mil multilayer film optimized for bioprocess production applications. Film materials are consistent throughout the product range, and are free of materials of animal origin.

Standard OneSUM Technical Specifications

3D Single Use Mix Bags									
	10L	25L	50L	100L	200L	500L	650L	1000L	2000L
Powder Port	3" TC	3" TC	3" TC	3" TC	3" TC	3" TC	3" TC	3" TC	3" TC
Inlet Port	1/2" HB	1/2" HB	1/2" HB	3/4" HB	3/4" HB	3/4" HB	3/4" HB	3/4" HB	3/4" HB
Drain Port	1/2" HB	1/2" HB	1/2" HB	3/4" HB	3/4" HB	3/4" HB	3/4" HB	3/4" HB	3/4" HB
Instrument Ports	3/4" HB	3/4" HB	3/4" HB	3/4" HB	3/4" HB	3/4" HB	3/4" HB	3/4" HB	3/4" HB
Other Top Ports	1/2" HB	1/2" HB	1/2" HB	1/2" HB	1/2" HB	1/2" HB	1/2" HB	1/2" HB	1/2" HB
Length (in)	7.40	10.00	12.75	16.00	20.25	27.50	30.00	34.50	43.40
Width (in)	7.40	10.00	12.75	16.00	20.25	27.50	30.00	34.50	43.40
Height (in)	11.75	16.00	19.70	25.00	31.00	42.00	45.50	53.00	67.00
Max Volume (L)	10.50	26.25	52.50	105.00	208.25	520.50	671.00	1033.75	2068.00

Contact Us



Office Address:
195 Industrial Drive Northampton, MA
01060 United States



Phone: 413.320.4650
Fax: 413.320.4663



Email:
sales@purityone.com

Purity One™ manufactures single-use and custom hose solutions that are critical to improving quality of life and overall wellness for people around the world. With our combined technical expertise and cleanroom assembly capabilities, we focus on providing a level of service and quality-assurance that is unparalleled in the global life sciences, biopharmaceutical and pharmaceutical industries.

195 Industrial Drive
Northampton MA 01060

(413)320-4650

sales@purityone.com

purityone.com



IMPORTANT: Users are accountable for verifying that Purity One™ products are appropriate and safe for their intended purposes, and that the materials used conform to all relevant medical regulatory standards. Purity One™ disclaims any liability for product failures resulting from the improper use of materials supplied, whether in the design, construction, or application of the products in which these materials are utilized.